

Holographic Invisible LED Screen Instruction

— All-in-One Machine —

(With Colorlight A100)



 0755-86269679

CONTENTS

I. Precautions of All-in-One Machine	01
II. Description of All-in-One Machine	
1. Product description	03
2. Schematic diagram of product	03
3. Specification parameters	04
III. Application	05
IV. Instructions for Installation and Operation	
1. Schematic diagram of product components	07
2. Precautions	09
3. Instructions for installation and operation	10
V. Control System of All-in-One Machine	
1. System accessories	21
2. Connect the All-in-One Machine	22
3. Synchronous control	23
4. Asynchronous control	26
5. Synchronous playback settings on the computer	29

* Without our written permission, no unit or individual is allowed to extract, copy, in part or whole, this document without authorization, or transmit it in any form. In case of any problems in the process of using this product, please feel free to contact us and propose your valuable suggestions, for which we will sincerely appreciate and adopt them based on evaluation.

I. Precautions of All-in-One Machine

1、Precautions.

- Follow the operation steps in this instruction, and read the instruction carefully before using our products;
- Transport and install this product with care to avoid collision or vibration. Improper transport and installation will cause damage to the LED holographic screen;
- To prevent the product from scratching and damage, do not scratch the LED modules with sharp and hard objects;
- Place the product on a flat ground during installation;
- Connect all power cables, partial connection can start the screen, but results in damage;
- Handle the modules carefully during dismantling, fractured modules can only be replaced.

2、Use and maintenance.

- Assign professional technicians to perform monthly on-site inspection and maintenance;
- Avoid using the product in environment of high temperature, high humidity, strong acid or alkali;
- Avoid violent collision during handling to protect the product from damage;
- Do not use the product for a long time in poor heat dissipation environment;
- Cut off the power immediately once water gets into the screen, do not use the product until all components are completely dried;
- Inspect the power supply interface to avoid wrong connection;
- Inspect the cables regularly to protect the interfaces from loosening and insects biting.

3、Important safety instructions.

1. To avoid possible danger, you are required to use this equipment according to regulations. In case of damage, non-professionals shall not open the equipment for repair without authorization, and shall contact our after-sales service in time.
2. Warning:
 - Keep the product away from water, and also do not place any objects containing liquid on the product;
 - Keep the product away from fire to prevent from burning;
 - Cut off the power immediately in case of strange noise, smoke or odor;
 - Abide all electrical safety standards on site;
 - Connect the product to power supply equipment against electric leakage and failure;
 - Transport, operate and store the product under wanted temperature and humidity;
 - Clean the product with soft cloth with a little neutral cleaning solution in maintenance;
 - Use specified accessories and have them installed and repaired by professionals;
 - Never do live-line work when dismantling the product.

4、Product certification

Please confirm and check with the relevant sales personnel of MUXWAVE For the certification of the products sold to the relevant countries and regions. Should you have any questions, feel free to contact MUXWAVE personnel at the first time for solution. The customer shall bear the relevant legal risk, if any, caused by use of the products.



II. Description of All-in-One Machine

1、Product description

“MUXWAVE” Holographic Invisible LED Screen employs self-developed innovative drive mode and product framework. Under the design concepts of “lighting”, “transparent” and “environmentally friendly”, it takes the design of ultra-low static power consumption as a breakthrough, and it is characterized by ultra-thin, high-definition, high-brightness and high-transparency. It can be installed on transparent glass in modular way. With more than 80% transparency, when holographic videos or 3D videos are played, the product presents a bare-eye VR visual effect. Holographic Invisible LED Screen is widely applied in applications such as urban digital landscapes, brand impressions, digital showrooms, landmarks, etc.

2、Schematic diagram of product

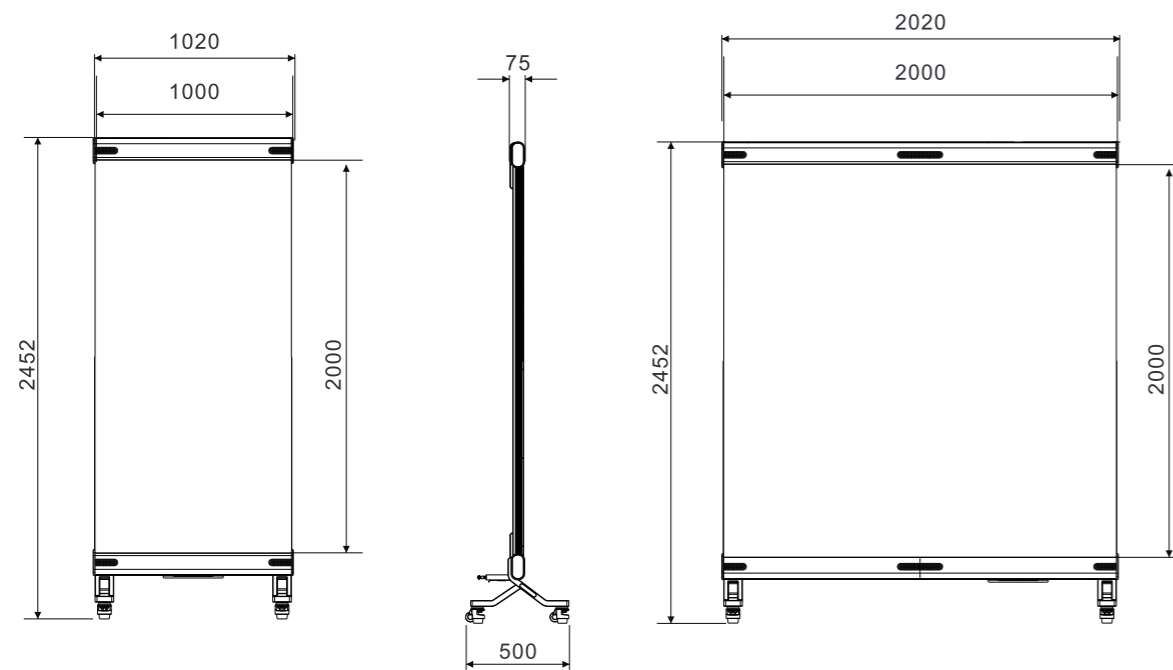

External dimensions: 1000*2000mm

External dimensions: 2000*2000mm

3、Specification parameters

Model	A3-2	A3-4
Pixel Pitch (mm)(horizontal / vertical)	P3.91 / P3.91	P3.91 / P3.91
Pixel Density(dot/m ²)	65536	65536
Transparency Rate	80%	80%
Display Dimension (mm) (w*h)	1000x2000	2000x2000
Profile Dimension (mm) (w*h)	1020x2230x75 1020x2452x500	2020x2230x75 2020x2452x500
Resolution (dot) (w*h)	256x512	512x512
Brightness(cd/m ²)	≥3000	≥3000
Weight(Kg/m ²)	40	60
Encapsulation Type	Light Board & Driving Board Integrated	
Scanning Mode	Static Driving (Single Pixel Single Control)	
Lifespan	≥100,000.00 hours	
Pixel Configuration	16bit	
Maximum Power Consumption (w/m ²)	1000	
Average Power Consumption (w/m ²)	375	
Control System	Colorlight / Novastar	
Input Voltage	AC100~240V 50/60 Hz	
Working Voltage for Module	DC 4.2V ± 0.2V	
Working Temperature	Temperature 0°C~50°C	
Working Humidity	Humidity: 20% -85% (Without Condensation)	
Storage Temperature	Temperature -20°C~60°C	
Storage Humidity	Humidity: 10% -85% (Without Condensation)	
Protetion Degree	IP 20	
Frame Material	Aviation Aluminum Alloy	
Installation Environment	Indoor	
Packing Way	Pearl Cotton+Wooden case/Flight Case	

Statement: The relevant parameters in the table are subject to real-time update, and the data is for reference only. Upgrade will be made without further notice. Operating this equipment may cause radio interference in the residential environment.

III. Application

1、All-in-One Machine has two types, respectively Hanging Up type and Floor Standing type (with wheels at the bottom).



2、System diagram: (taking Colorlight A100 as an example).

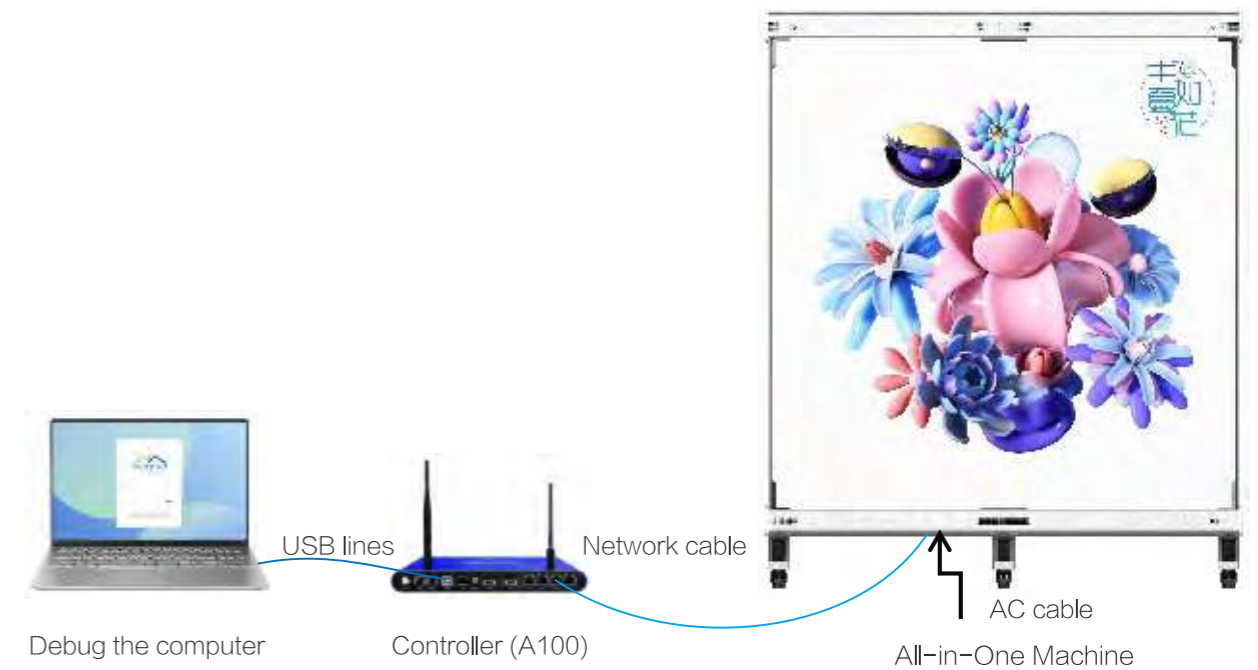

Output interface for the Gigabit network port of controller	Connect LED display and controller	Interface type: RJ 45
USB interface of controller	Connect the control computer (for equipment debugging)	Interface type: USBTYPE B square port
Video source interface of controller	Video source input and monitoring port (synchronous)	Interface type: HDMI, DVI, DP, 3G-SDI, etc

Selection of Control System: Our products support Colorlight/NovaStar's LED Control Systems. Colorlight LEDVISION Version 7.9 and NovaStar NovaLCT Version 5.4.4.6 are customized software for our company, software download from the official websites don't support the configuration files. If you have special needs, please contact related sale members of MUXWAVE, we apologize for any inconvenience caused.

IV. Instructions for Installation and Operation

1. Schematic diagram of product components

Structural Assembly Instruction: Face the screen (see the following picture) to distinguish between the bottom horizontal beam, namely the bottom control box (power supply cable interface at the bottom), the top horizontal beam, namely the top control box (hanging hooks at the top), the left vertical beam (AC power supply cable cascade inside), the right vertical beam (network cable cascade inside).

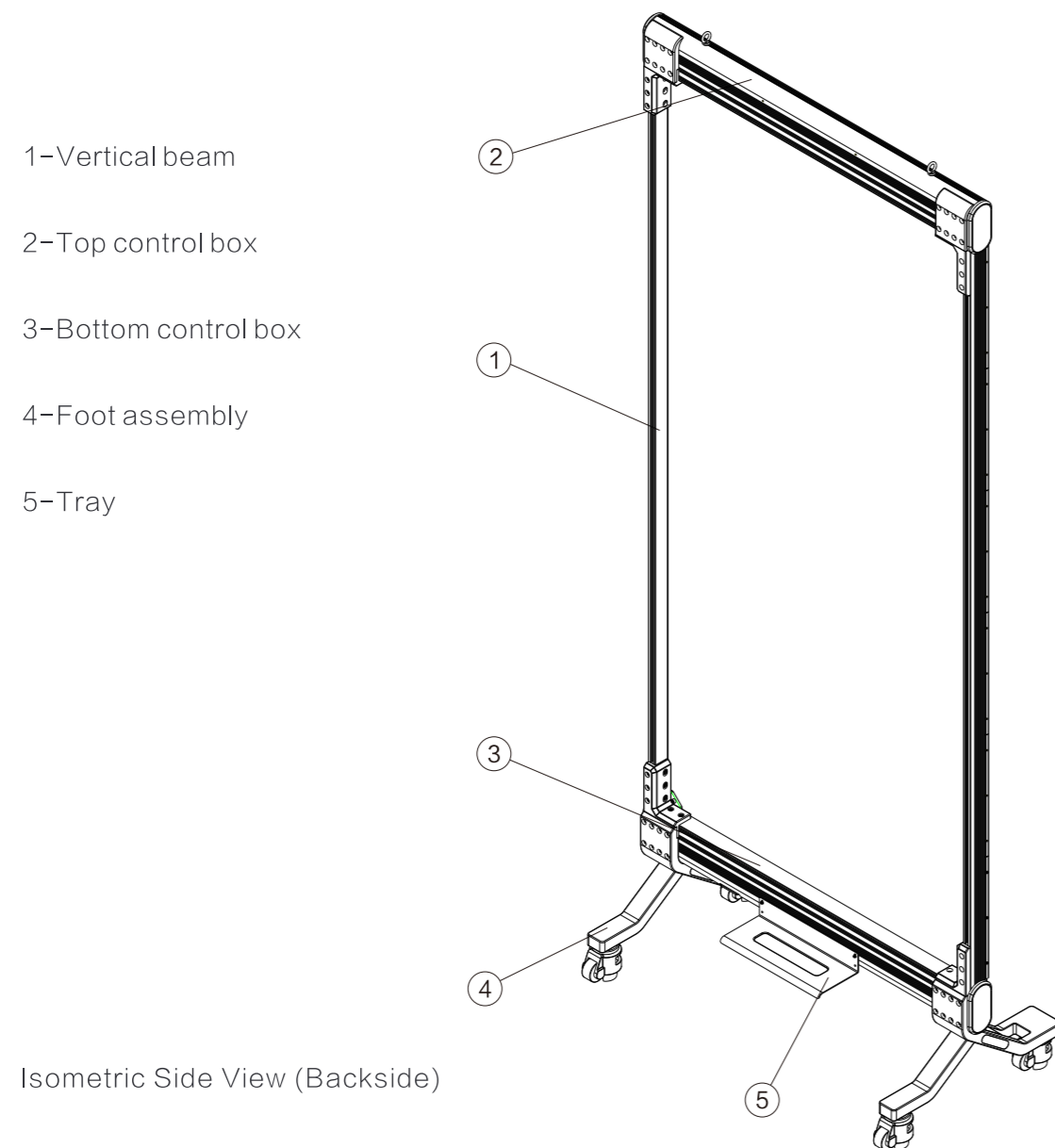

Note: The top control box and bottom control box of 2*2m All-in-One Machine are 2m long, and those of 1*2m All-in-One Machine are 1m long, and the two All-in-One Machines share other parts.

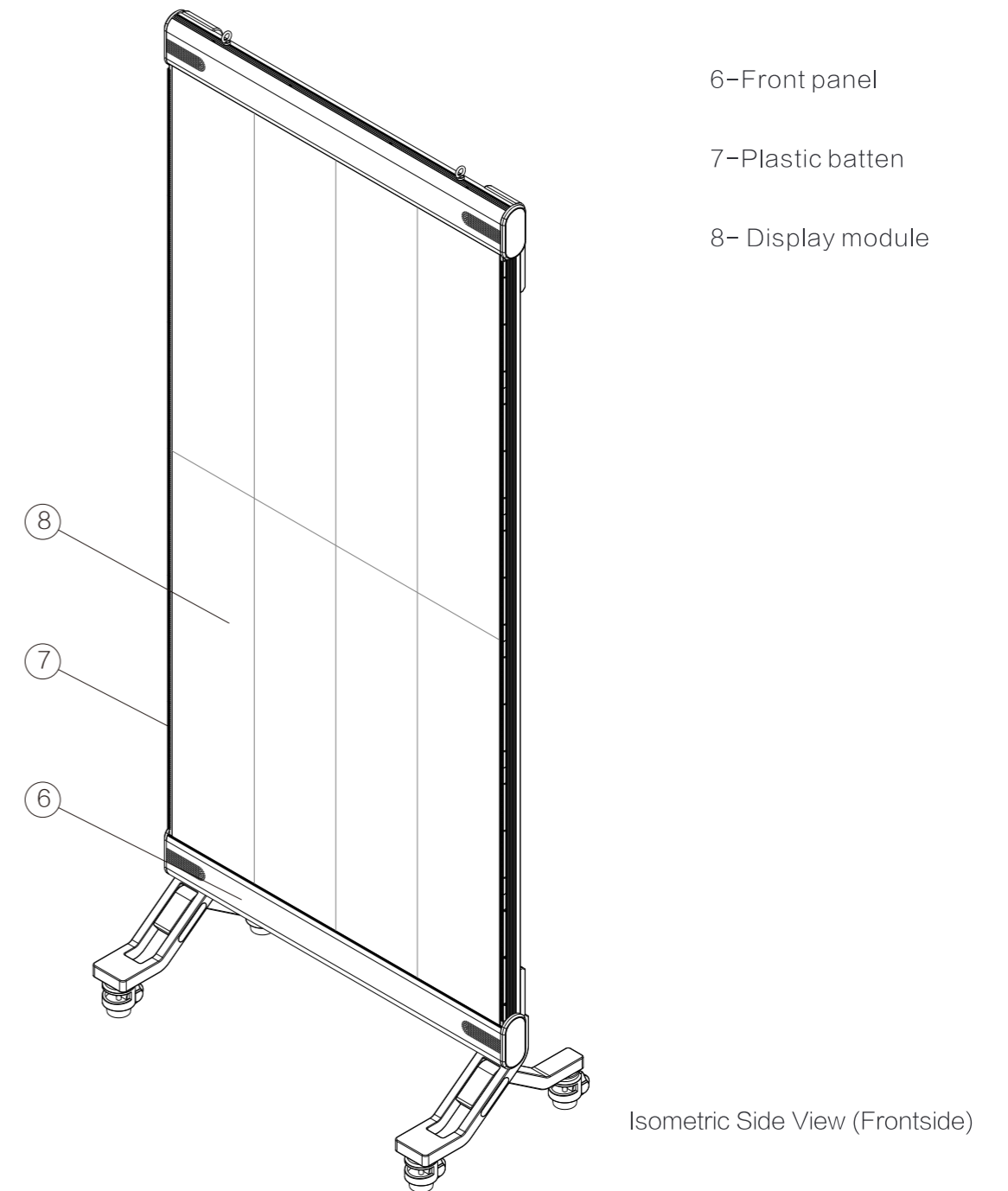

2、Precautions:

Before using the equipment, read all safety precautions to ensure that the product is safely and correctly used!

- To prevent personal accidents, do not open the cover, and no one other than our technicians is allowed to open the upper cover of the equipment.
- It is required to use the power supply and accessories approved by the manufacturer. The product supports DC12V power input. The power adapter provided together with this product should be used.
- It is required to protect functional interfaces against contact with other charged objects, because this product is an electronic product. Functional interfaces in contact with other live objects may cause damage to circuit components, thus affecting the normal use of the product.
- Keep away from flammable and explosive materials and other dangerous goods. Do not operate and use this product in an flammable and explosive environment!
- This product is not water-proof. Do not use the product with direct contact with liquid or in a wet environment.

2、Safety protection measures

To avoid personal injury and equipment damage, please abide the safety instructions of A100 controller.

3、Unpacking and inspection

After unpacking, check against the enclosed packing list, and contact the corresponding sales personnel in time in the event of any incomplete accessories.

3、Instructions for installation

(these steps can also be referred to repair and replace the components of the All-in-One Machine)

The 1*2m All-in-One Machine will be packaged as a whole machine (except for special situations), while the 2*2m All-in-One Machine will be disassembled and then be packaged, therefore please follow these steps to install.



Step 1. Structural breakdown diagram of All-in-One Machine.

Structural Assembly Instruction: Face the screen (see the following picture) to distinguish between the bottom horizontal beam, namely the bottom control box (power supply cable interface at the bottom), the top horizontal beam, namely the top control box (hanging hooks at the top), the left vertical beam (AC power supply cable cascade inside), the right vertical beam (network cable cascade inside).

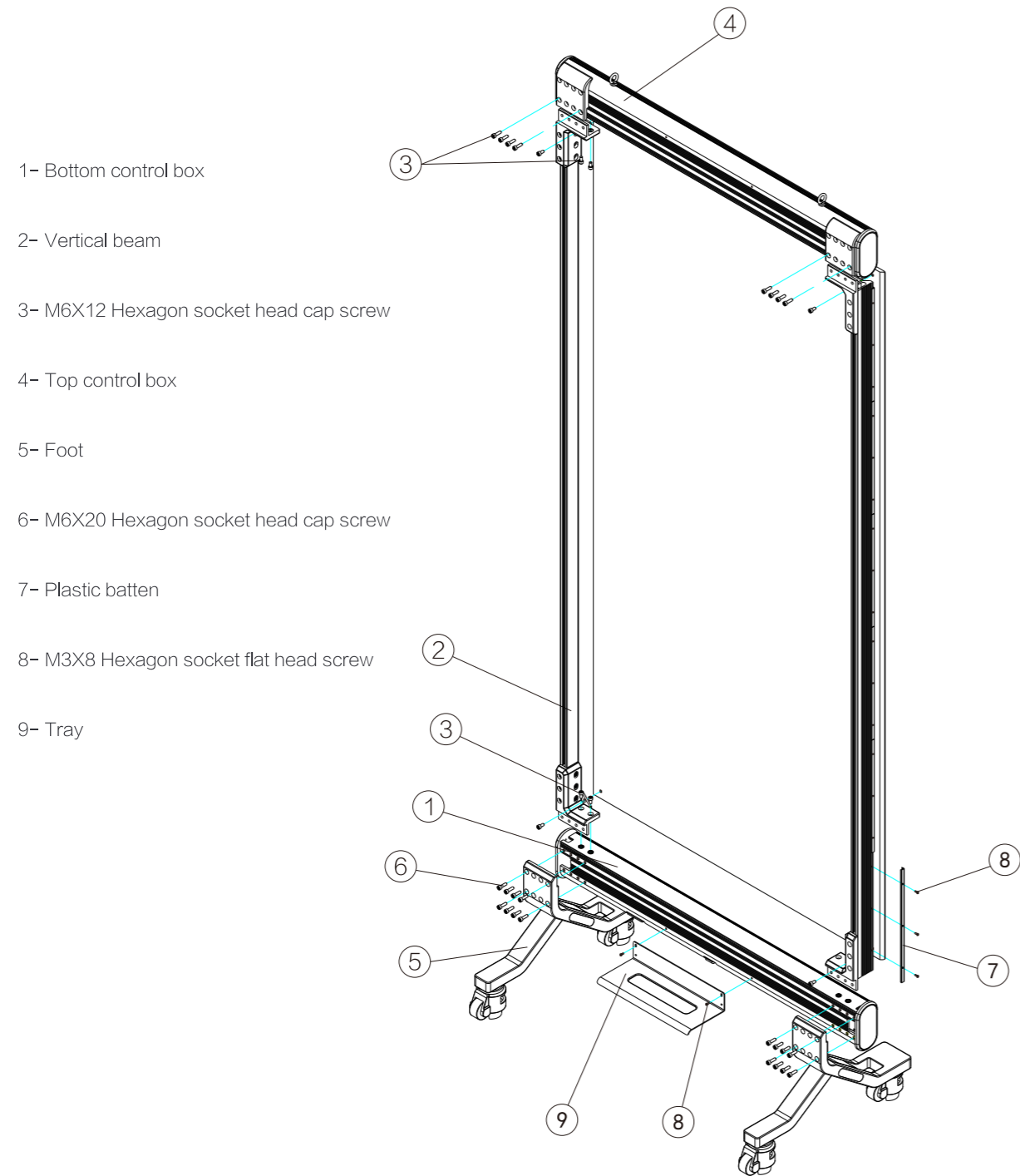

Step 2. First, fix and install the vertical beam and control box.

Align the bottom control box (Part 1) and vertical beam (Part 2) with the installation hole as shown in the figure, and fasten them with screws (Part 3). The vertical beams on both sides are assembled in the same way. Then fasten the top crossbeam with screws (part 3) and complete the installation of control box.

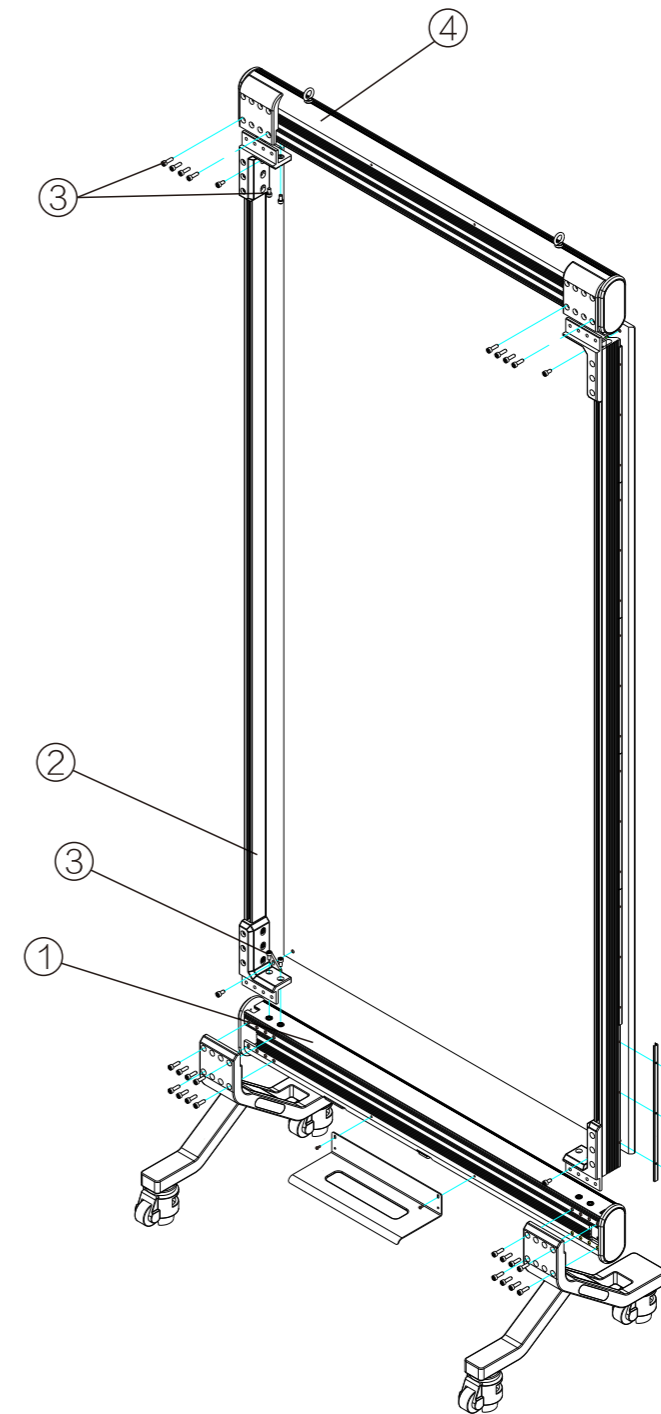

Step 3. Connect the signal and power cable between the upper and lower cross beams.

Ensure that, during assembly in step 2, after the signal network cable and power cable of the upper and lower crossbeam pass through the vertical beam, connect both ends of Registered jack of the network cable to the RJ45 network port of adapter board, and the power cable to AC connection port of the nearest adjacent power supply.

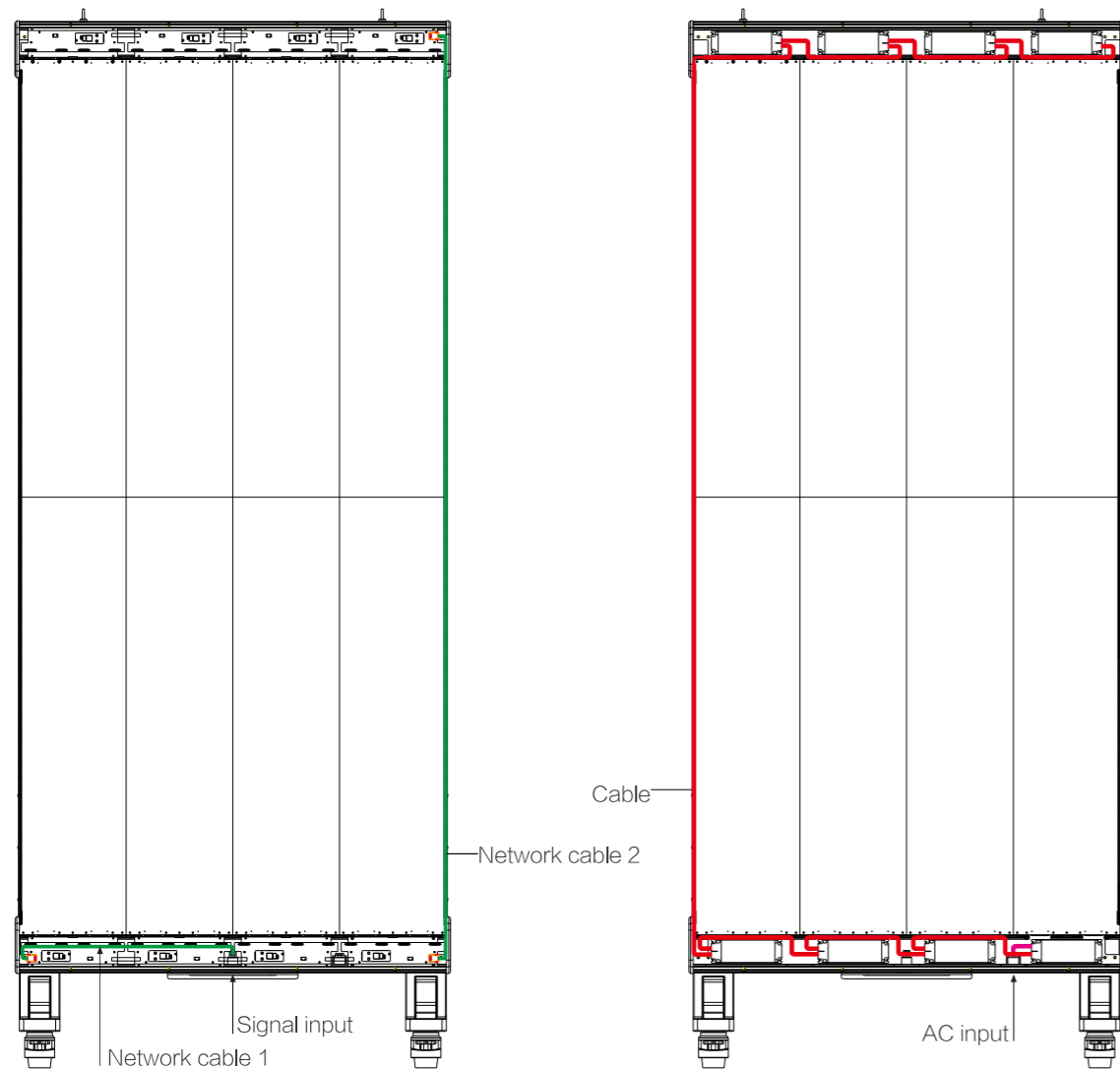

Internal signal and power wiring diagram of the complete machine

Note: During installation, distinguish the internal routing of vertical beam, and according to the direction of internal signal line of control box, install the vertical beam with network cable in place and then connect the upper and lower control box signals, with the vertical beam with power cable installed on the other side (as shown in the figure).



* AC Power Supply Connection Precautions:
Red/Brown cable is the live wire (L),
Blue cable is the neutral wire (N),
Yellow-green bicolor cable is the ground wire (PE),
Power cables' connection orders must be followed.



DC Power Supply Connection Precautions:
Red cable is the positive pole (V+),
Black cable is the negative pole (GND),
Power cable' s connection orders must be followed.

Step 4. Foot installation.

As shown in the figure, align the foot (part 5) and the above completed structural member with the installation hole, fasten them with screws (part 6), and install the feet on both sides in the same way. Complete the foot installation.

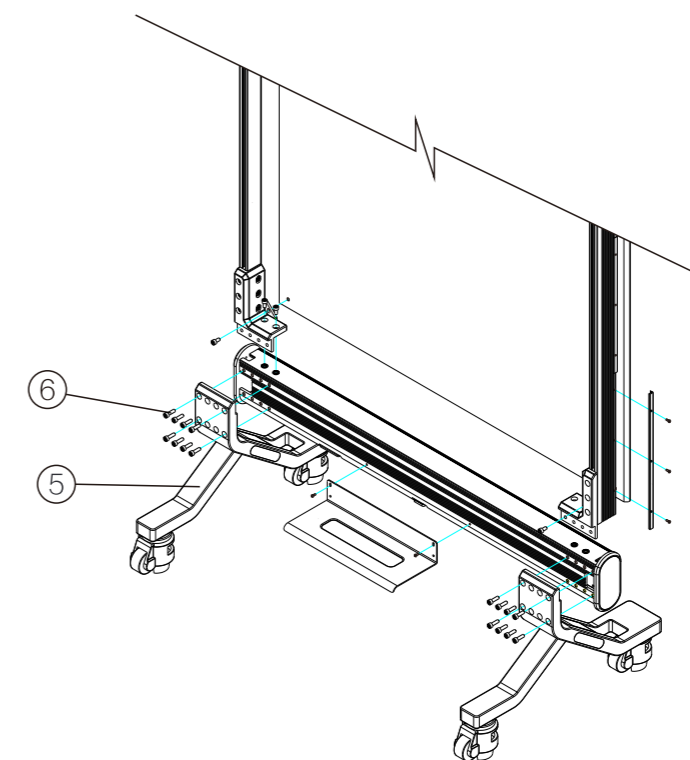

Step 5. Installation of display module.

- 01. Remove the fixing screws (Part 2) fixing the front panel of control box, and take off the front panel from the control box (Part 1);
- 02. Connect the FPC flexible cable and DC power cable at the end of the control box with the display module, assemble those cables of the upper and lower display module (Part 3) in turn, and then fix the display module with screws (Part 4) in succession;
- 03. Assemble and restore the position of the front panel of control box. When assembling the front panel, buckle the front panel into the buckle position on the beam (attention should be paid to the buckle position of the beam).

Module Installation Direction:

In All-in-One Machine, A modules are installed at the bottom while B modules are installed at the top, and their positions cannot be reversed, please pay attention to the label on the module, as the following pictures say, A14 is A module, B018 is B module.

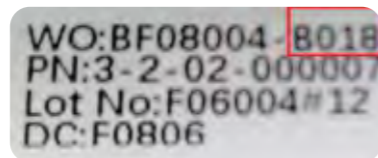
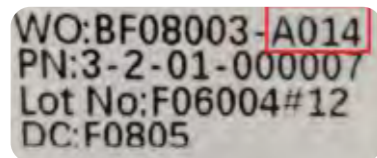

Buckle Installation Direction:

Pay attention to the direction of the buckles during installation, the buckles should be installed without touching the pins of the beads, otherwise there will be risk of short-circuit.

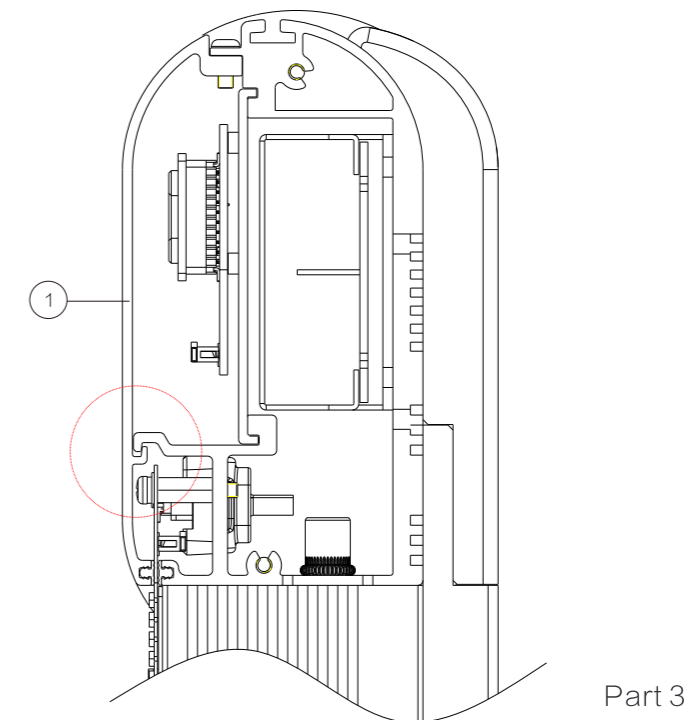
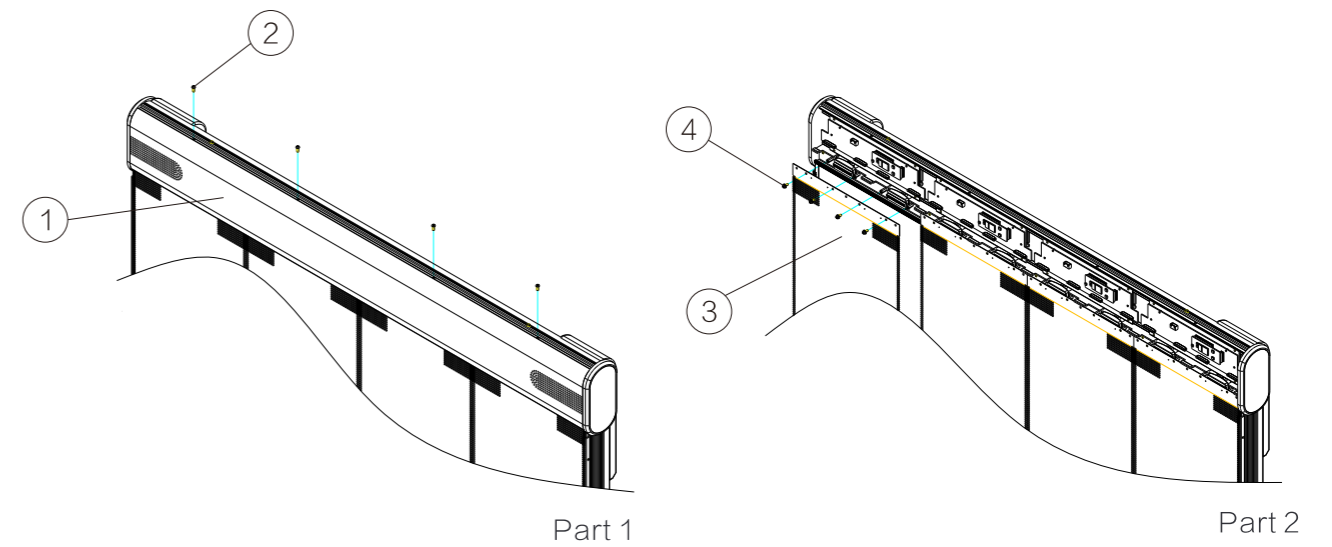
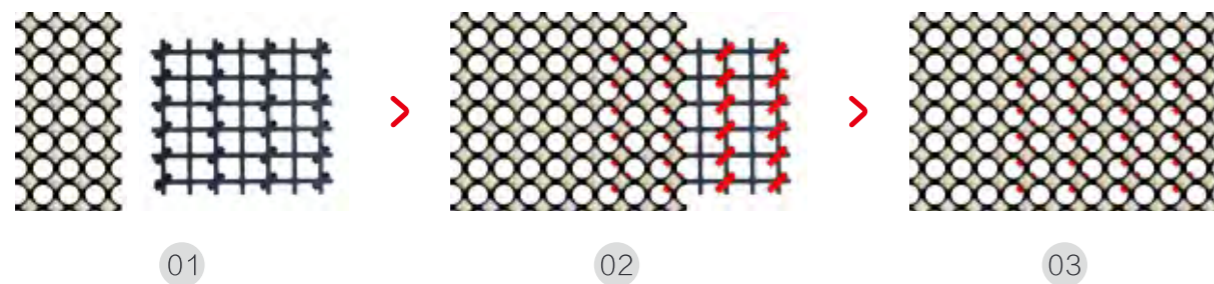

Step 6. Install the plastic battens.

Align the whole row of openings of plastic battens (Part 7) with the display module lamp, and the side mounting holes with the threaded holes of vertical beam, and fasten the plastic batten with screws (Part 8). During assembly, it is recommended to, based on the splicing positions of the upper and lower display modules, install three plastic battens in sequence, 6 on each side and 12 on both sides. It is required to match the position of openings with that of the display module lamp to prevent lamp beads from falling off during assembly.

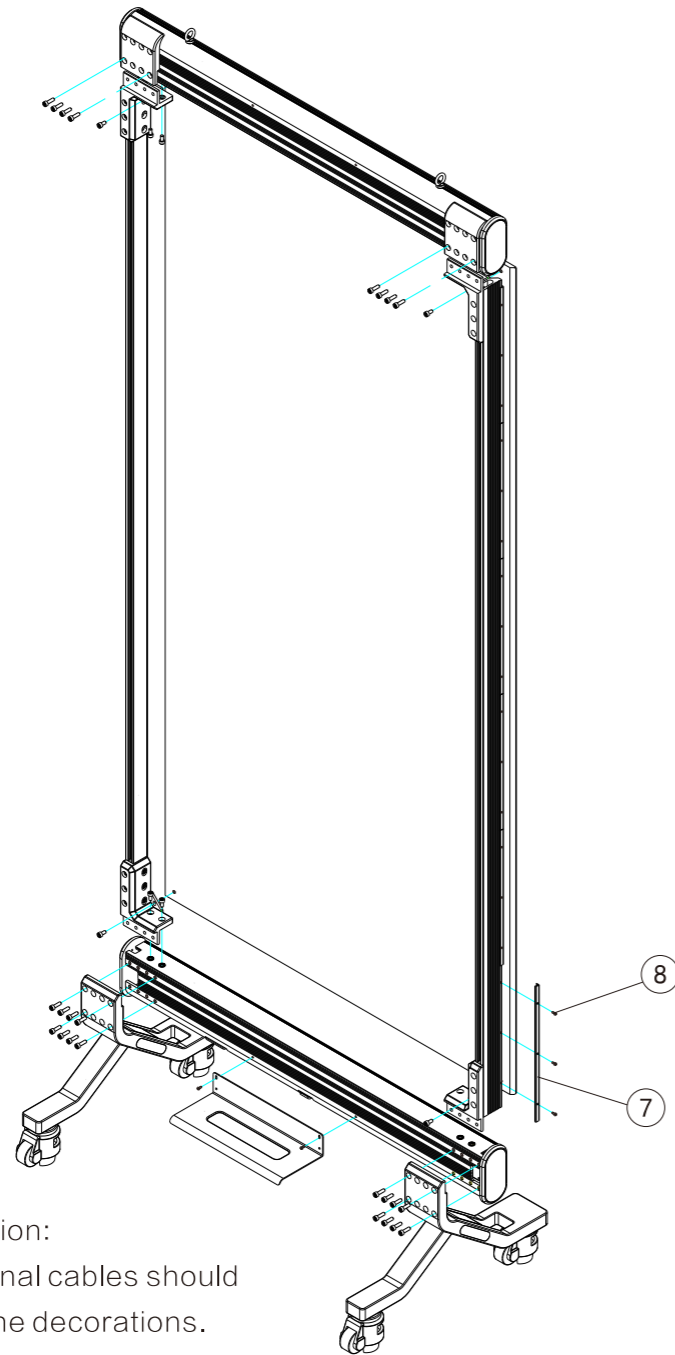

Decoration Precaution:
Connectors and signal cables should not be pressed by the decorations.

Step 7. Install the tray.

After aligning the mounting holes of the tray (part 9) with the threaded holes on the bottom control box, fasten them with screws (part 8) to complete the installation.

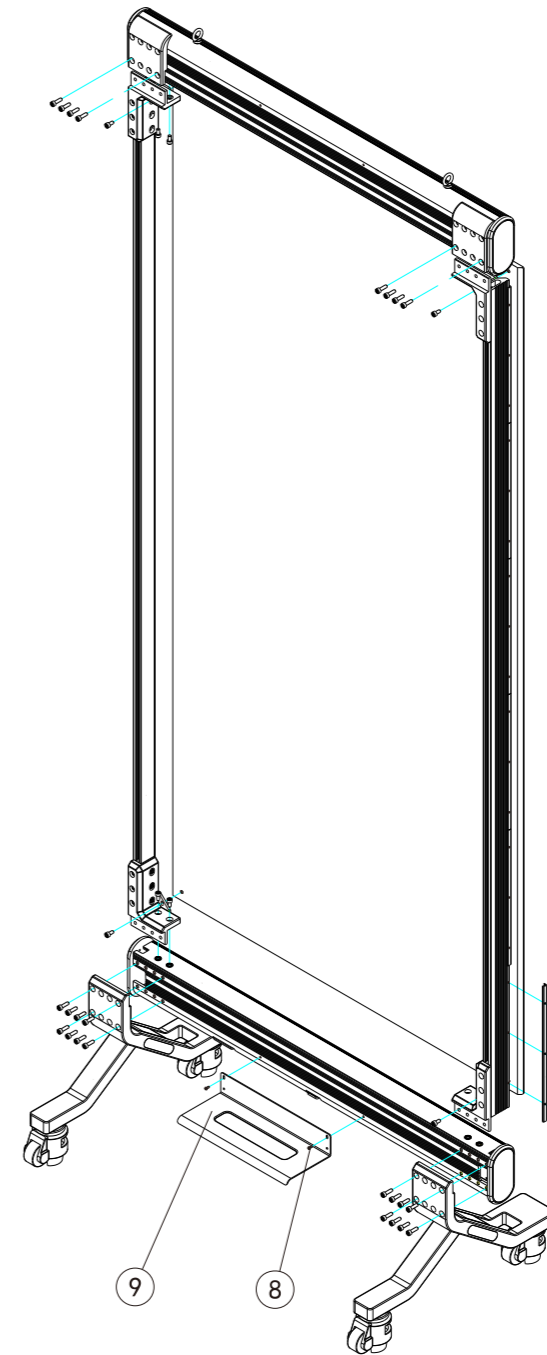

Step 8. Connect the main cable and network cable.

Each control box is provided with an AC power socket (model: C20), which connects the plug of main cable (model: C19) with AC power socket. Connect one end of network cable to RJ45 network port of control box (as shown in the figure), and the other end to the signal input interface of All-in-One Machine. After confirming that the power supply and system work normally, complete the assembly.

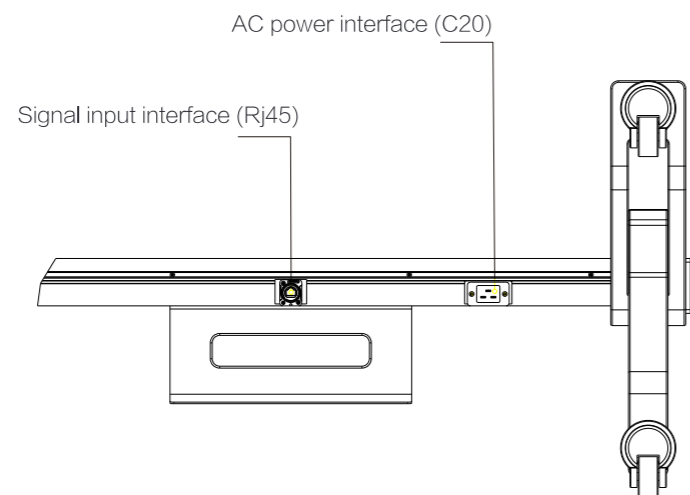
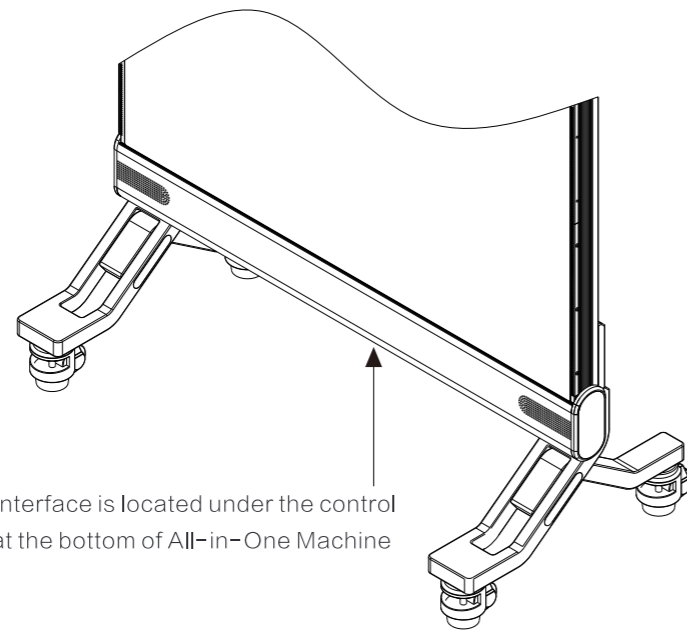

Step 9. Instructions for spot check and replacement of receiving card, adapter board, switching power supply and signal cable.

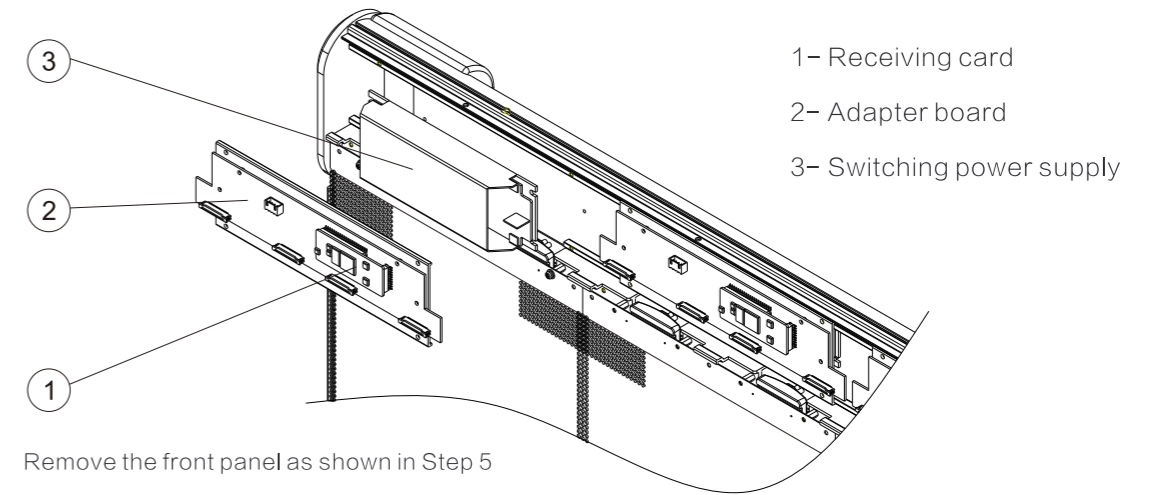

01. Replace the receiving card.

Hold both sides of the receiving card by hand, pull out the card by force, and replace it with a new one. When inserting the card, confirm that the connector corresponds to the pin position on the adapter board one by one, and insert the receiving card to complete the replacement.

02. Replace the adapter board.

Remove the adapter board by unscrewing the fixing screws (4) on the board with a cross screwdriver, align the new adapter board with the hole position according to the original position, and replace the locking screws.

03. Replace the switching power supply.

First remove the structural parts of the mounting bracket of adapter board, then remove the cable at the AC end of the power supply to be replaced. Remove the screws fixing the power supply to be replaced with a cross screwdriver, replace the power supply with a new one, connect the AC cable, lock the screws fixing the power supply, and complete the replacement.

04. Check for exceptions.

If, in the process of use, abnormal signal transmission occurs, remove the front panel to check the 8PFPC flexible flat cables between adapter boards for poor contact, and if necessary, replace them with new ones.

V、Control System of All-in-One Machine

1、System accessories



Main cable

DVI cable

Controller A100

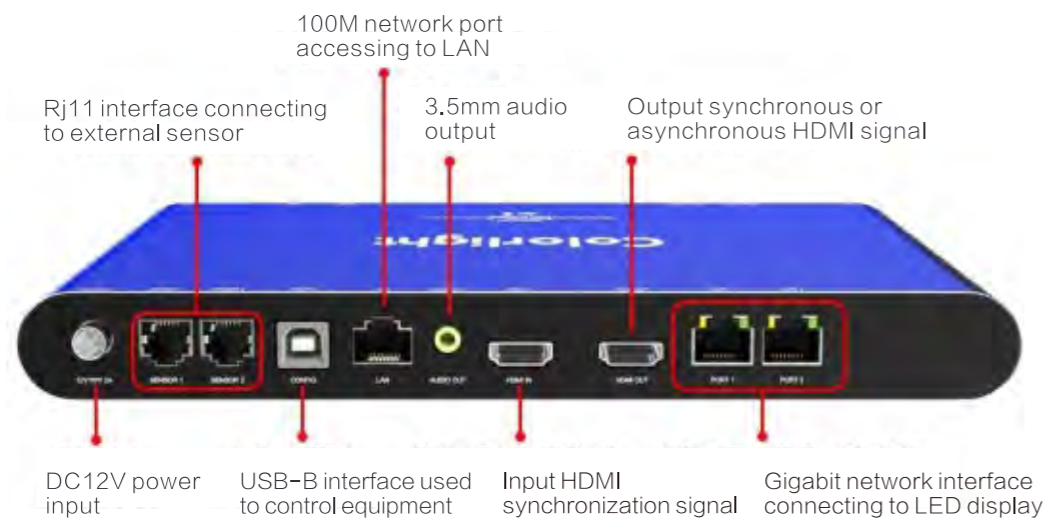
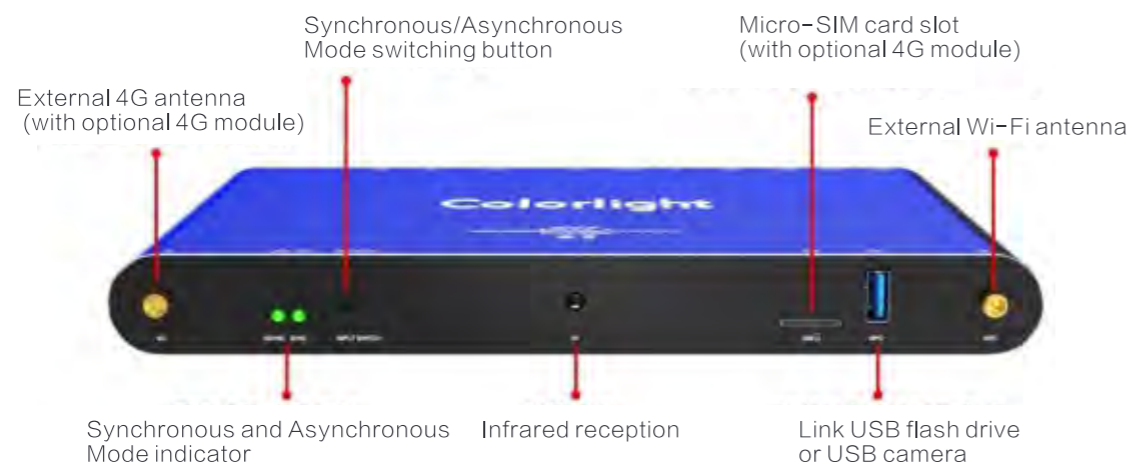

2、Connect the All-in-One Machine

Step 1. Connect the power supply correctly for the screen.

AC plug must not be loose. Confirm whether a normal voltage is available before powering on.

11. Turn on the screen

Firstly, please turn on the video controller or processor, after successful operation, then turn on the power supply of the screen.

2. Turn off the screen

Firstly, please turn off the power supply of the screen, then quit the control software, and turn off the control computer.



Step 2. Connect the player with All-in-One Machine correctly.

Connect USB debugging cable, and the 12V DC power supply of Controller A100 box.

An arbitrary connection sequence is acceptable.

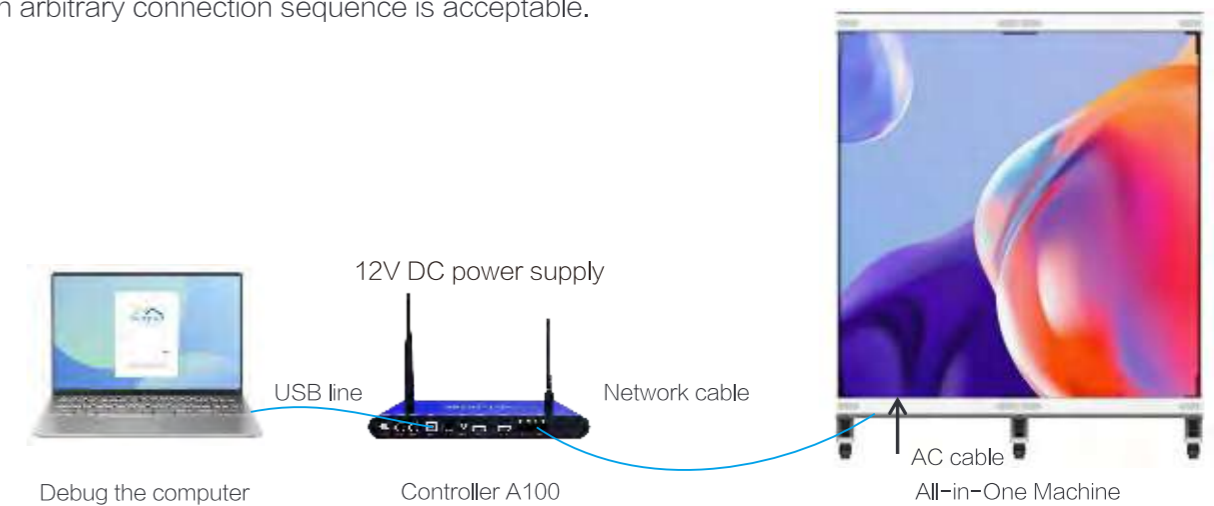

3、Synchronous control

Synchronous control refers to the LED display control system in which the content displayed on the display screen is synchronized in real time with the computer display screen. An area of the computer monitor displays exactly the same content as the LED display.

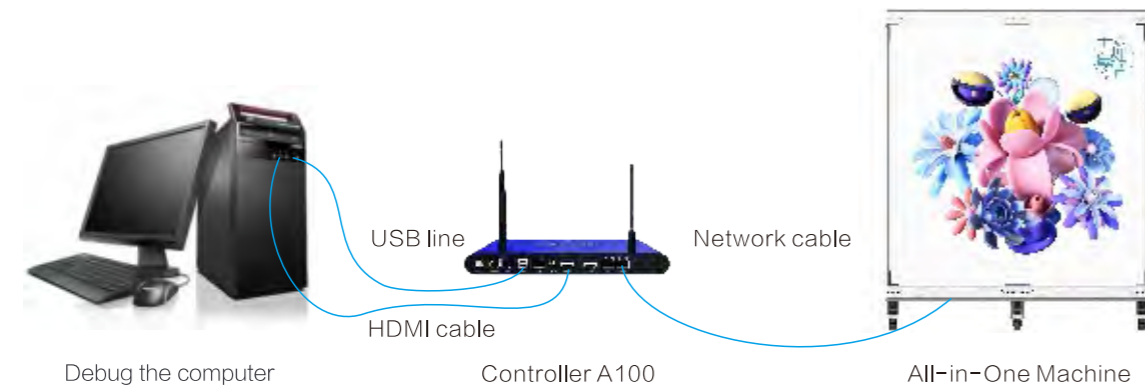

Schematic diagram of synchronization control system

Note: Users can download the latest PlayerMaster installation package on the official website: www.colorlightinside.com [Service support] - [Download zone], decompress and then just install it correctly.



Computer editing and sending program page.
(computer software: PlayerMaster)

01. Open PlayerMaster, click “+” in the [Program Management] main interface, set the resolution width and height of the screen (the same as the screen resolution), and click OK to enter the Program Editing area;



"Program"	basic unit, which can be independently assigned to the playback device for playback
"Program page"	It is possible to provide different window layouts in the same program by setting different program pages or, of course, by setting different programs.
"Window"	Multiple program windows can be added to the program page. Different program windows will have different contents, and the program windows under the same program page are played at the same time. The layout of program is dependent on the window.
"Material"	The specific content displayed on the LED screen, including video, pictures, Gif text files, and Office files.

Note: In each LED screen, program pages and contents in the same program window are played in sequence, while the program windows under the same program page are parallel and played simultaneously.

02. Click Add Programs page to add different types of programs and materials according to actual needs. After editing, click Save and click Publish;



03. Wait for the progress bar and after the release is finished, the content just released will be displayed on the LED display screen and the program is sent by the computer.



4. Asynchronous control

Asynchronous control system, also called offline control system, stores the display data edited by the computer in the display control system in advance. The normal display of LED display screen will not be affected after the computer is powered off. Simply put, a control card is used and the content is edited with a mobile phone/tablet, or a USB flash drive is used to include the content in the control card. The display screen is only controlled by a control card, dispense with computer control.



Schematic diagram of asynchronous control system

Note: Users can search [LED Smart APP] on the mobile terminal [Application Market] to download and install the necessary supporting software. Also users can scan the following QR code for installation.



IOS QR code



Android QR code

Edit and send program page by mobile phone. (Mobile app: LED)

01. Turn on the mobile phone to set up WLAN and connect the hotspot with the word a100, for example, a100-2436, and enter password 123456789.



02. Activate the software LED wizard on the mobile phone, enter the interface, click [Program], and click in the upper right corner of the program to enter Program Editing.



03. Click “+” Add to set the resolution width and height of the screen (the same as the screen resolution), and click OK to enter the next interface.



04. Set the width and height as the actual resolution of the screen, and click “+” Add to enter the next interface.

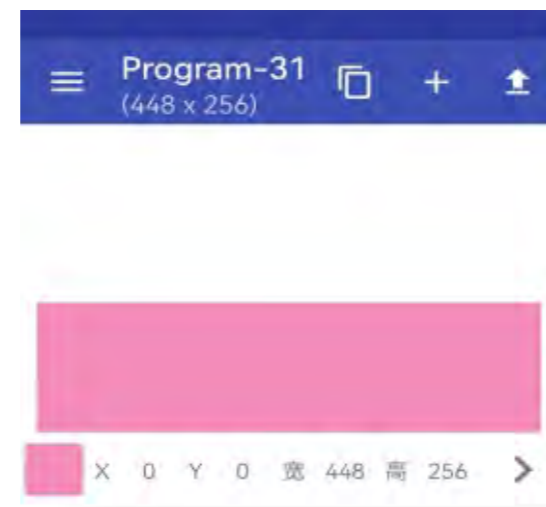

05. Add different types of programs and materials according to actual needs. After selecting the materials, click OK to enter the next interface.



06. Click in the upper right corner of the program, and click Upload to enter the next interface.



07. Check the playback box used. Click in the upper right corner of the program, wait for the progress bar, observe whether the content played on the screen is abnormal, and complete program sending by mobile phone.

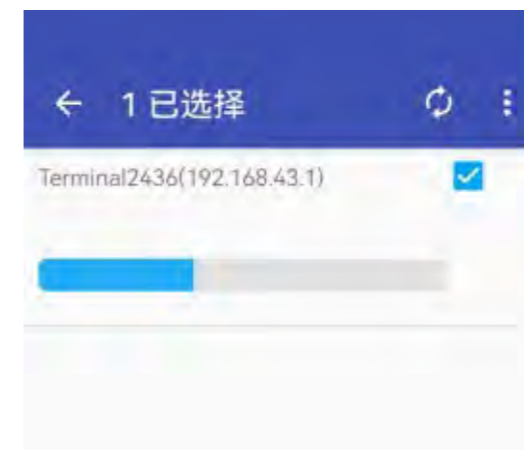

5、Synchronous playback settings on the computer.

(Computer software: PlayerMaster and LEDVISION)

01. Open PlayerMaster, click the connected A100 playback box, and click Advanced Settings in the lower menu bar. Password: 168. In the control area of network interface, set network interface 1: width 256, height 512, network interface 2: line starting point 512, width 1440, height 388. Click Save to enter the next interface.



02. Click Advanced Settings, password: 168. Click screen parameters, change HDMI input resolution to width: 1400, height: 900, click Send, and enter the next interface after completion.



03. Click Advanced Settings, Password: 168. Click Screen Settings, change screen resolution to width: 1400, height: 900, and click Apply below and restart. Wait for the playback box to restart about 30 seconds.



04. Find the System-Screen on the computer used, and the display resolution, and set it to 1400X900.

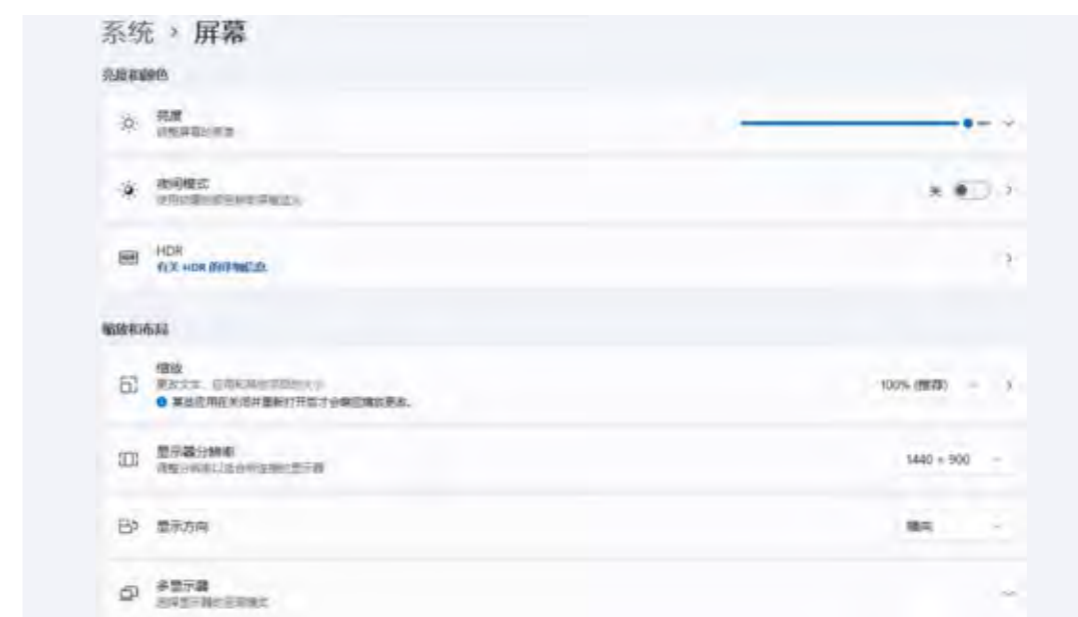

05. Open LEDVISION, find and change the screen size to the actual screen width: 256, height: 512, and click Modify. After debugging, please refer to the User Manual of LEDVISION for the LEDVISION broadcast program page.



During use, you can get quick access to more help information through the following ways.

Service Hotline: 0755-86269679

Email: info@meixiwei.com

Get more help information quickly by scanning the following QR code.

Visit: www.muxwave.com for more information.



Shenzhen Muxwave Technology Co., Ltd.

4thFloor East Building 4, Shenzhen Software Park, No.2 Gaoxinzhong 2nd Road,
Nanshan District, Shenzhen, P.R.China.

✉ info@meixiwei.com 🌐 www.muxwave.com